



O-I France SAS
 2 Rue Maurice Moissonnier
 69120 Vaulx-en-Velin, France
 Tel. +33 (0)426686500

CONTAINER & MOULD DESIGN
 EUROPE

NOTES:
 THIS DRAWING IS THE PROPERTY OF O-I AND
 MUST NOT BE REPRODUCED OR DISCLOSED
 WITHOUT O-I WRITTEN AUTHORIZATION.

DIMENSIONS EXPRESSED IN mm
 ONLY TOLERANCED DIMENSIONS ARE GUARANTEED.

MANUFACTURING MARKINGS SHOWN ARE FOR ILLUSTRATIVE
 PURPOSES ONLY, ACTUAL MARKINGS ON CONTAINER
 MAY DIFFER, DEPENDANT ON LOCAL LEGISLATION.

16/07/2024

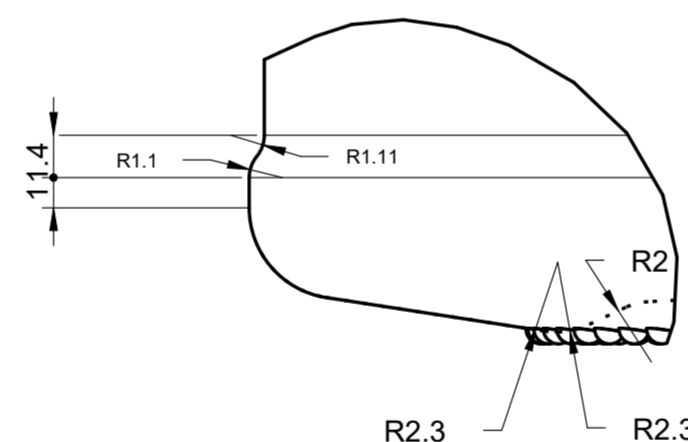
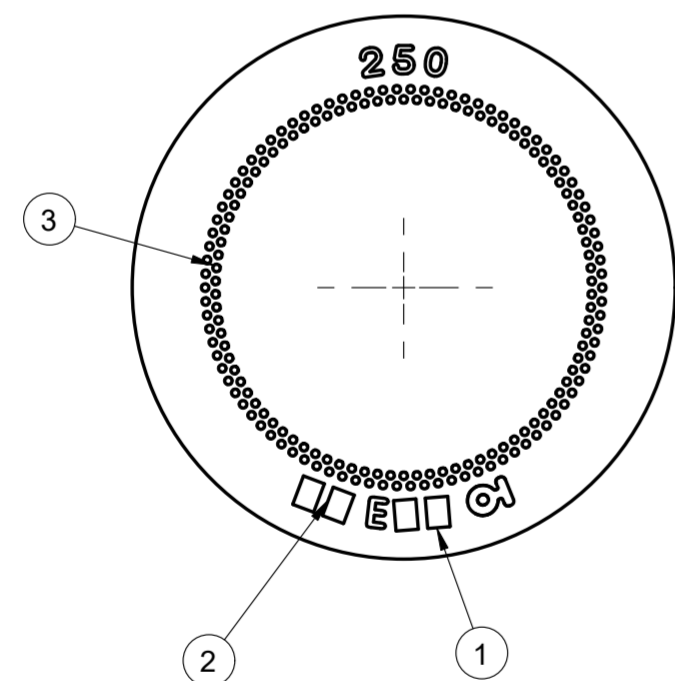
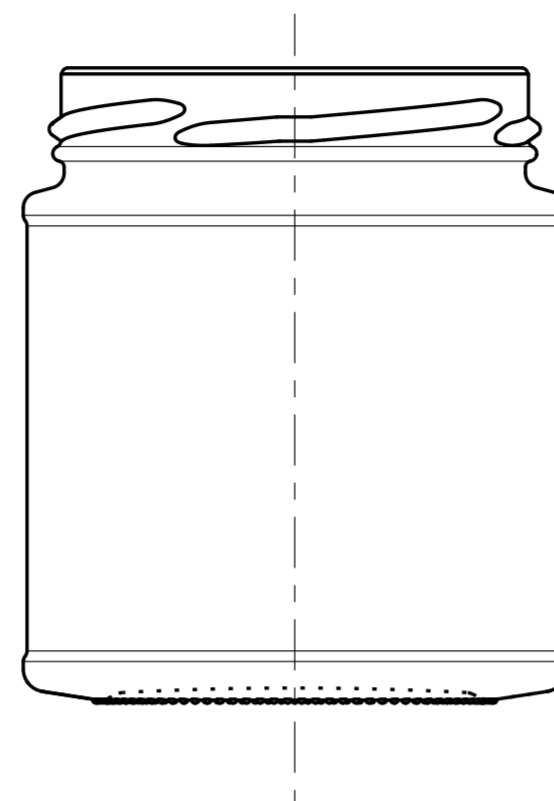
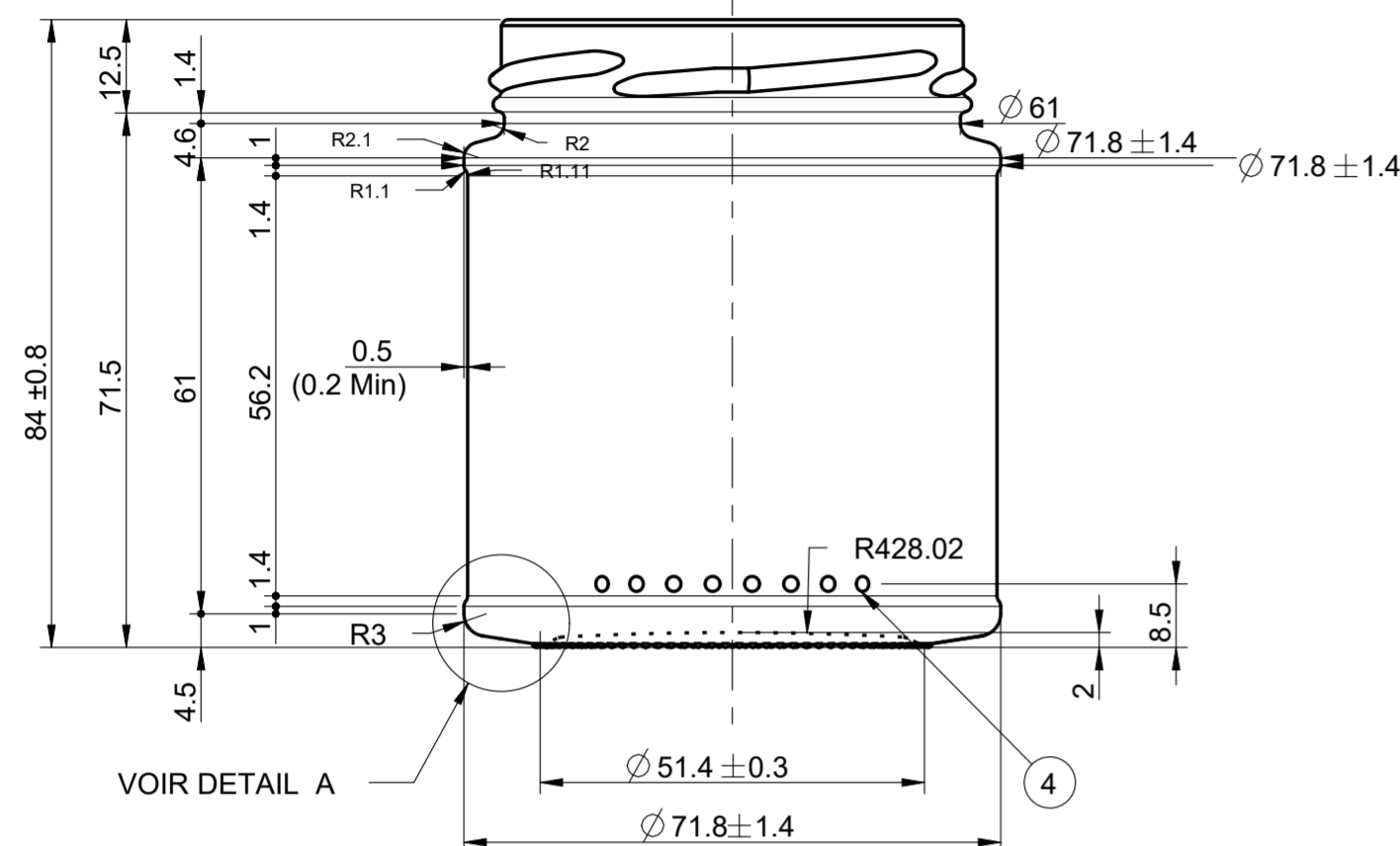

DETAIL A
 ECHELLE 4/1



1 = TRADEMARK
 2 = CAVITY No.
 3 = STIPPLING
 THE SHAPE OF STIPPLES IS ONLY AN
 INDICATION AND THE CONSTRUCTION IS AT
 THE PRODUCTION PLANT DISCRETION.
 4 = CAVITY CODE

SCALE 1:1

HEAT TREATMENT XX °C maxi	CARBONATION 0 g CO2/l maxi
VERTICAL LOAD 150 daN maxi	THERMAL SHOCK 42 °C maxi
CATEGORY FOOD	TILT ANGLE 33.7°
MAX. VERTICALITY TOLERANCE 1.5 mm	MEASURING CONTAINER NO
FINISH SAP NUMBER 4963	FINISH REF. CETIE GME 20-06 1995
MINIMUM THROUGH BORE mm	MAX FILLING TUBE Ø mm
CONTAINER OVERFLOW CAPACITY (BRIMFUL)	
250ml ± 6ml	
CONTAINER RATED CAPACITY (FILLPOINT)	
NA	
CONTAINER WEIGHT	
150g APPROX.	
FINISH DESIGNATION EU_66_GME 20-06_H125_4963	MAX GAS VOLUME
PROCESS RETURNABLE NO	DESIGN REF. OI EU n° 34437

STANDARD
 25 CL 8 REF II TO66

DESIGNER	EBL	DATE	04/06/2020
CHECKED		DATE	
DRAWING NUMBER	200178	MOULD/SAP NUMBER	200178

No	DATE	REVISIONS	DESIGN/CHECK
	10/06/20	ADDED SHAPE CODE ON THE VERSION 02	EBL
	04/06/20	MODIFY SOME DIMENSIONS	EBL