

GLASS IS LIFE™

O-I makers of pure, sustainable, brand-building glass packaging

O-I Manufacturing France
 84 bd du 11 Novembre 1918 - BP 1228
 69811 Villeurbanne Cedex, France
 Tel. +33 (0)428886500

**CONTAINER & MOULD ENGINEERING
 EUROPE**

NOTES:
 THIS DRAWING IS THE PROPERTY OF O-I AND
 MUST NOT BE REPRODUCED OR DISCLOSED
 WITHOUT O-I WRITTEN AUTHORIZATION.

ONLY TOLERANCED DIMENSIONS ARE GUARANTEED.

MANUFACTURING MARKINGS SHOWN ARE FOR ILLUSTRATIVE
 PURPOSES ONLY. ACTUAL MARKINGS ON CONTAINER
 MAY DIFFER, DEPENDANT ON LOCAL LEGISLATION.

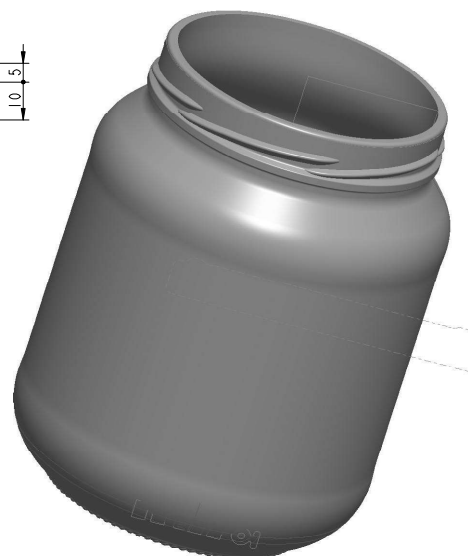
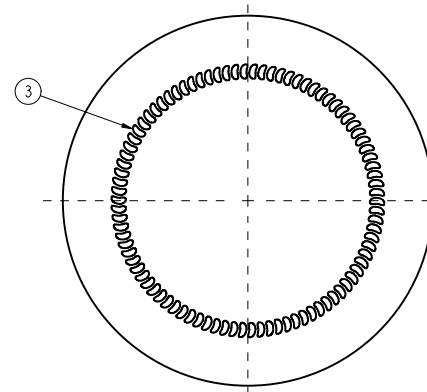
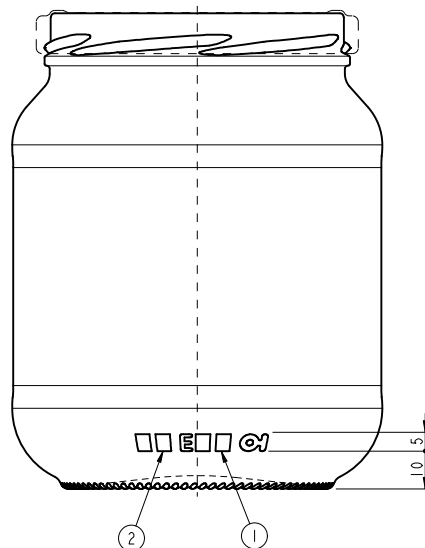
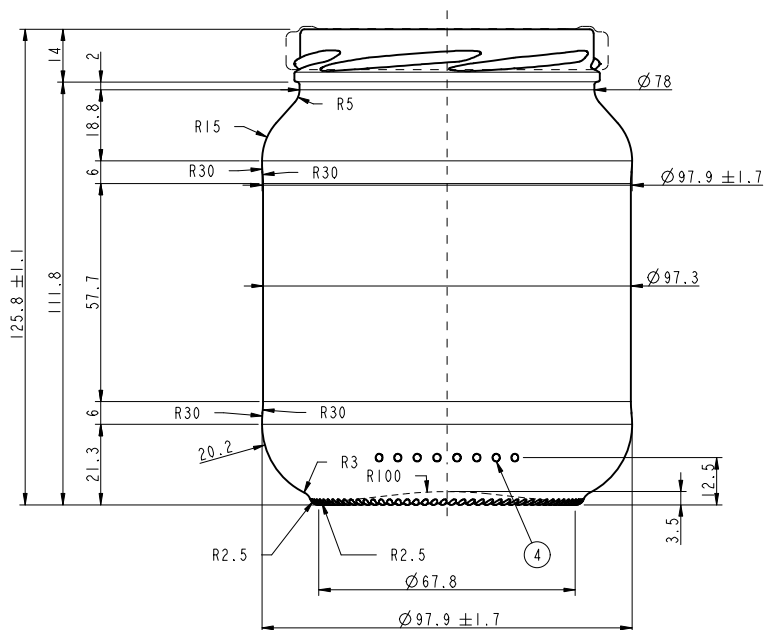

José María Castro Avilés
 Quality Mgr. Marché Food France-Espagne

23 Enero 2020

1 = TRADEMARK
 2 = CAVITY No.
 3 = STIPPLING
 THE SHAPE OF STIPPLES IS ONLY AN
 INDICATION AND THE CONSTRUCTION IS AT
 THE PRODUCTION PLANT DISCRETION.
 4 = CAVITY CODE

SCALE 1:1

HEAT TREATMENT XX °C maxi	CARBONATION XX g CO2/l maxi
VERTICAL LOAD 150 daN maxi	THERMAL SHOCK 42 °C maxi
CATEGORY FOOD	TILT ANGLE 30.11°
MAX. VERTICALITY TOLERANCE 1.6 mm	MEASURING CONTAINER NO
FINISH SAP NUMBER 3743	FINISH REF. CETIE GME 20-09 1995
MINIMUM THROUGH BORE . mm	MAX FILLING TUBE Ø . mm
CONTAINER OVERFLOW CAPACITY (BRIMFUL) 720ml ± 10ml	
CONTAINER RATED CAPACITY (FILLPOINT) NA	
CONTAINER WEIGHT 290g APPROX.	
FINISH DESIGNATION FR_82_GME 20-09_H150_3743	MAX GAS VOLUME
PROCESS RETURNABLE NO	DESIGN REF. 14-7061

**STANDARD
 72 CL POT FB TO 82**

DESIGNER	BCO	DATE	29/08/13
CHECKED		DATE	
DRAWING NUMBER 130900	MOULD/SAP NUMBER 013616		

No	DATE	REVISIONS	DESIGN/CHECK
	29/08/13	REPRISE KBE ANNULE ET REMPLACE N° PLAN 6185-01 B	BCO